

559 F.3d 1317, 90 U.S.P.Q.2d 1257
(Cite as: 559 F.3d 1317)



United States Court of Appeals,
Federal Circuit.
LARSON MANUFACTURING COMPANY OF
SOUTH DAKOTA, INC., Plaintiff-Appellant,
v.
ALUMINART PRODUCTS LIMITED and Cham-
berdoor Industries, Inc., Defendants-Cross Appel-
lants.
Nos. 2008-1096, 2008-1174.

March 18, 2009.

Background: Patent owner brought action against competitors alleging infringement of patent claiming a door with a moving glass insert. In a bench trial, the United States District Court for the District of South Dakota, [Lawrence L. Piersol, J., 513 F.Supp.2d 1102](#), found the patent unenforceable due to inequitable conduct during the reexamination proceedings, but denied competitors' motion for attorney fees, [529 F.Supp.2d 1059](#). Both parties appealed.

Holdings: The Court of Appeals, [Schall](#), Circuit Judge, held that:

- (1) district court clearly erred in finding three items of prior art not disclosed during reexamination proceeding material, but
- (2) third and fourth office actions of the Patent and Trademark Office (PTO) from patent owner's continuation application were material.

Affirmed in part, reversed in part, vacated in part, and remanded.

[Linn](#), Circuit Judge, filed a concurring opinion.

West Headnotes

[\[1\] Patents 291](#)

[291 Patents](#)

[291IV](#) Applications and Proceedings Thereon
[291k97](#) k. Patent Office and Proceedings Therein in General. [Most Cited Cases](#)
A patent may be rendered unenforceable for inequitable conduct if an applicant, with intent to mislead

or deceive the examiner, fails to disclose material information or submits materially false information to the Patent and Trademark Office (PTO) during prosecution.

[\[2\] Patents 291](#)

[291 Patents](#)

[291IV](#) Applications and Proceedings Thereon
[291k97](#) k. Patent Office and Proceedings Therein in General. [Most Cited Cases](#)
To successfully prove inequitable conduct by an applicant in patent prosecution, an accused infringer must present evidence that the applicant (1) made an affirmative misrepresentation of material fact, failed to disclose material information, or submitted false material information, and (2) intended to deceive the Patent and Trademark Office (PTO); in addition, at least a threshold level of each element must be proven by clear and convincing evidence.

[\[3\] Patents 291](#)

[291 Patents](#)

[291IV](#) Applications and Proceedings Thereon
[291k97](#) k. Patent Office and Proceedings Therein in General. [Most Cited Cases](#)
Information concealed from the Patent and Trademark Office (PTO) during a patent prosecution may be material, for purposes of proving inequitable conduct, even though it would not invalidate the patent; however, a withheld otherwise material reference is not material if it is merely cumulative to, or less relevant than, information already considered by the examiner.

[\[4\] Patents 291](#)

[291 Patents](#)

[291IV](#) Applications and Proceedings Thereon
[291k97](#) k. Patent Office and Proceedings Therein in General. [Most Cited Cases](#)
Inequitable conduct in a patent prosecution requires not intent to withhold, but rather intent to deceive; the intent element of the offense is proven by inferences drawn from facts, with the collection of inferences permitting a confident judgment that deceit has

559 F.3d 1317, 90 U.S.P.Q.2d 1257
(Cite as: 559 F.3d 1317)

occurred.

[5] Patents 291 🔑97

291 Patents

291IV Applications and Proceedings Thereon

291k97 k. Patent Office and Proceedings

Therein in General. [Most Cited Cases](#)

If the requirements of materiality and intent are met to demonstrate inequitable conduct in a patent prosecution, the court must then determine whether the questioned conduct amounts to inequitable conduct by balancing the levels of materiality and intent, with a greater showing of one factor allowing a lesser showing of the other.

[6] Patents 291 🔑324.54

291 Patents

291XII Infringement

291XII(C) Suits in Equity

291k324 Appeal

291k324.54 k. Presumptions and Discretion of Lower Court. [Most Cited Cases](#)

Patents 291 🔑324.55(2)

291 Patents

291XII Infringement

291XII(C) Suits in Equity

291k324 Appeal

291k324.55 Questions of Fact, Verdicts, and Findings

291k324.55(2) k. Clearly Erroneous Findings. [Most Cited Cases](#)

When, after a trial, the court has made factual findings as to materiality and deceptive intent during a patent prosecution, those factual findings are reviewed for clear error, and the decision of the ultimate issue of inequitable conduct is reviewed for abuse of discretion.

[7] Federal Courts 170B 🔑853

170B Federal Courts

170BVIII Courts of Appeals

170BVIII(K) Scope, Standards, and Extent

170BVIII(K)5 Questions of Fact, Verdicts and Findings

170Bk850 Clearly Erroneous Findings

of Court or Jury in General

170Bk853 k. Definite and Firm Conviction of Mistake. [Most Cited Cases](#)

A factual finding is clearly erroneous when, although there is evidence to support the finding, the reviewing court on the entire evidence is left with the definite and firm conviction that a mistake has been committed.

[8] Federal Courts 170B 🔑812

170B Federal Courts

170BVIII Courts of Appeals

170BVIII(K) Scope, Standards, and Extent

170BVIII(K)4 Discretion of Lower Court

170Bk812 k. Abuse of Discretion. [Most Cited Cases](#)

An abuse of discretion occurs when: (1) the trial court's decision is clearly unreasonable, arbitrary, or fanciful; (2) the court's decision is based on an erroneous construction of the law; (3) the court's factual findings are clearly erroneous; or (4) the record contains no evidence upon which the court rationally could have based its decision.

[9] Patents 291 🔑97

291 Patents

291IV Applications and Proceedings Thereon

291k97 k. Patent Office and Proceedings

Therein in General. [Most Cited Cases](#)

District court clearly erred in ruling that prior art in the form of product and marketing material disclosing different sizes and designs of retractable roller insect screen systems, which could be installed on doors, and patent disclosing a “pull bar” extending into the screen tracks and between weather stripping, was material and not cumulative of another prior art patent already before the patent reexamination panel of the Patent and Trademark Office (PTO), in finding patent claiming a door with a moving glass insert unenforceable due to inequitable conduct during the reexamination proceedings; prior art patent before the reexamination panel disclosed the same elements leading to the district court's finding that the other prior art references were material, specifically it showed a pull rod extending into a channeled horizontal track to guide the screen panel.

[10] Patents 291 🔑97

559 F.3d 1317, 90 U.S.P.Q.2d 1257
(Cite as: 559 F.3d 1317)

[291 Patents](#)

[291IV](#) Applications and Proceedings Thereon

[291k97](#) k. Patent Office and Proceedings Therein in General. [Most Cited Cases](#)

District court clearly erred in finding that prior art literature, consisting of product and instructive material for a “self-storing window screen,” was not cumulative of prior art that was already before the reexamination panel of the Patent and Trademark Office (PTO), in finding patent claiming a door with a moving glass insert unenforceable due to inequitable conduct during the reexamination proceedings; prior art patent before the reexamination panel showed the same elements that the district court found material in the prior art literature, namely a pull bar in channels, with a screen sliding in the channels.

[\[11\] Patents 291](#) 

[291 Patents](#)

[291IV](#) Applications and Proceedings Thereon

[291k97](#) k. Patent Office and Proceedings Therein in General. [Most Cited Cases](#)

Third and fourth office actions of the Patent and Trademark Office (PTO) from continuation application of owner of patent claiming a door with a moving glass insert, directed toward similar screen door technology, which both contained examiner comments and rejections, were material and not cumulative of first two office actions which were already before the reexamination panel, for purposes of determining whether patent owner committed inequitable conduct; third office action contained specific explanation about prior art patent in connection with “extending into screen tracks” limitation, and the fourth office action articulated a new rejection of the “extending into screen tracks” limitation in view of prior art patents.

[\[12\] Patents 291](#) 

[291 Patents](#)

[291IV](#) Applications and Proceedings Thereon

[291k97](#) k. Patent Office and Proceedings Therein in General. [Most Cited Cases](#)

Materiality does not presume intent, for purposes of determining whether an applicant committed inequitable conduct in patent prosecution, and nondisclosure, by itself, cannot satisfy the deceptive intent element; rather, the alleged infringer must prove by

clear and convincing evidence a specific intent to deceive the Patent and Trademark Office (PTO).

[\[13\] Patents 291](#) 

[291 Patents](#)

[291IV](#) Applications and Proceedings Thereon

[291k97](#) k. Patent Office and Proceedings Therein in General. [Most Cited Cases](#)

While deceptive intent can be inferred from circumstantial evidence, for purposes of determining whether an applicant committed inequitable conduct in patent prosecution, the circumstantial evidence must still be clear and convincing; further, the inference must not only be based on sufficient evidence and be reasonable in light of that evidence, but it must also be the single most reasonable inference able to be drawn from the evidence to meet the clear and convincing standard.

[\[14\] Patents 291](#) 

[291 Patents](#)

[291IV](#) Applications and Proceedings Thereon

[291k97](#) k. Patent Office and Proceedings Therein in General. [Most Cited Cases](#)

Just as merely withholding a reference cannot support an inference of deceptive intent, as required to show inequitable conduct in patent prosecution, so too an accused infringer cannot carry its threshold burden simply by pointing to the absence of a credible good faith explanation.

[Patents 291](#) 328(2)

[291 Patents](#)

[291XIII](#) Decisions on the Validity, Construction, and Infringement of Particular Patents

[291k328](#) Patents Enumerated

[291k328\(2\)](#) k. Original Utility. [Most Cited Cases](#)

[2,107,755](#), [3,244,222](#), [5,540,476](#), [6,082,432](#), [6,640,869](#). Cited as Prior Art.

[Patents 291](#) 328(2)

[291 Patents](#)

[291XIII](#) Decisions on the Validity, Construction, and Infringement of Particular Patents

[291k328](#) Patents Enumerated

559 F.3d 1317, 90 U.S.P.Q.2d 1257
(Cite as: 559 F.3d 1317)

[291k328\(2\)](#) k. Original Utility. [Most Cited Cases](#)
[6,618,998](#). Cited.

***1320** Charles H. De La Garza, Chaz De La Garza & Associates, LLC, of Austin, TX, argued for plaintiff-appellant.

[Alan W. Kowalchyk](#), Merchant & Gould P.C., of Minneapolis, MN, argued for defendants-cross appellants. With him on the brief were [Kristine M. Boylan](#) and [Joshua P. Graham](#).

Before [SCHALL](#), [CLEVENGER](#), and [LINN](#), Circuit Judges.

Opinion for the court filed by Circuit Judge [SCHALL](#). Concurring opinion filed by Circuit Judge [LINN](#).

[SCHALL](#), Circuit Judge.

This is a patent case. Larson Manufacturing Company of South Dakota, Inc. (“Larson”), appeals the final judgment of the United States District Court for the District of South Dakota dismissing its suit against Aluminart Products Limited and Chamber-door Industries, Inc. (together, “Aluminart”), for infringement of claims 14 and 21 of Larson’s [U.S. Patent No. 6,618,998](#) (the “998 patent”). Ex Parte Reexamination Certificate [U.S. Patent No. 6,618,998 C1](#) (the “998 Reexamination Certificate”). The district court dismissed Larson’s suit after it held, following a bench trial, that the ‘998 patent was unenforceable due to inequitable conduct during reexamination proceedings before the U.S. Patent and Trademark Office (“PTO”) relating to the patent. [Larson Mfg. Co. v. Aluminart Prods. Ltd.](#), 513 F.Supp.2d 1102 (D.S.D.2007) (“[Inequitable Conduct Decision](#)”). The court found that Larson failed to disclose to the Reexamination Panel three items of prior art and two office actions issued in the prosecution of a continuation application that grew out of the application that resulted in the ‘998 patent. The court rejected Larson’s argument that the three items of prior art were cumulative of prior art which already was before the Reexamination Panel and therefore were not material, as well as its argument that the office actions were not material because all of the critical references noted in them already had been disclosed to the Reexamination Panel. After finding that Larson intended to deceive the Reexamination Panel, the court

balanced its findings of materiality and intent and found inequitable conduct.

Aluminart has filed a cross-appeal. In it, Aluminart argues that the district court erred in declining to find the case exceptional under [35 U.S.C. § 285](#) (1952). [Larson Mfg. Co. v. Aluminart Prods. Ltd.](#), 529 F.Supp.2d 1059 (D.S.D.2007) (“<http://www.westlaw.com/Find/Default.wl?rs=dfa1.0&vr=2.0&FindType=Y&SerialNum=2014528023Decision>”).

For the reasons set forth below, we conclude that the district court erred in finding that the three undisclosed items of prior art were material because they were not cumulative of prior art already before the Reexamination Panel. As a result, although we agree with the district court that the two office actions that Larson failed to disclose to the Reexamination Panel were material, we vacate the court’s finding of inequitable conduct and its resulting judgment in favor of Aluminart by reason of unenforceability of the ‘998 patent. We do so because the district court did not analyze Larson’s deceptive intent separately for each of the three items of prior art and two office actions. Rather, its determination that Larson intended to deceive the Reexamination Panel was based upon its finding that Larson failed to disclose collectively three items of prior art and two office actions, all of which the court determined were material. We hold today, however, that the three items of prior art which were not disclosed were cumulative of prior art already before the Reexamination Panel. Hence, they were not material. In contrast, we affirm the district court’s determination that the two office actions were material. Under these circumstances, the district court must redetermine***1321** the issue of intent and then, if it finds intent, balance anew materiality and intent to arrive at an ultimate conclusion as to whether there was inequitable conduct. We therefore remand the case to the district court for further proceedings. Our decision renders Aluminart’s cross-appeal moot.

BACKGROUND

I.

Larson manufactures door products, including storm doors with a retractable screen feature. The ‘998 patent, which issued from U.S. Application No.

559 F.3d 1317, 90 U.S.P.Q.2d 1257
(Cite as: 559 F.3d 1317)

10/212,465 (the “465 Application”) and is owned by Larson, is titled “Door With Variable Length Screen.” The patent claims a door with a moving glass insert. The insert travels in weather stripping-lined tracks and attaches to a spring-based rolled screen. '998 patent abstract. One embodiment of the invention is depicted in figures 10 and 10A of the patent, reproduced below.

Figure 10 shows a door **60** which has a header **62a**, doorjamb **62b** and **c** (only the latter marked), and a sill **62d**. *Id.* col.6 ll.32-33. The door carries a screen module **66**, shown in figure 10A and depicted in detail in figure 7B below, with a screen in it. The screen module can be coupled to the door's header, jambs, or

sill. *Id.* col.3 ll.18-19. A free end of the screen is coupled to the upper end of glass panel insert **64a**. *Id.* col.6 ll.38-41. In operation, the rolled screen retracts into the screen module and is hidden from view when the glass pane insert is raised toward the header and the screen module. When the glass insert is lowered toward the door sill, it travels into hollow panel **64b**, thereby allowing the screen to unroll into service. *Id.* col.6 ll.32-47. The glass panel insert moves up and down in weather stripping-lined insert tracks which are located in the doorjamb. *Id.* col.4 ll.51-54.

*1322

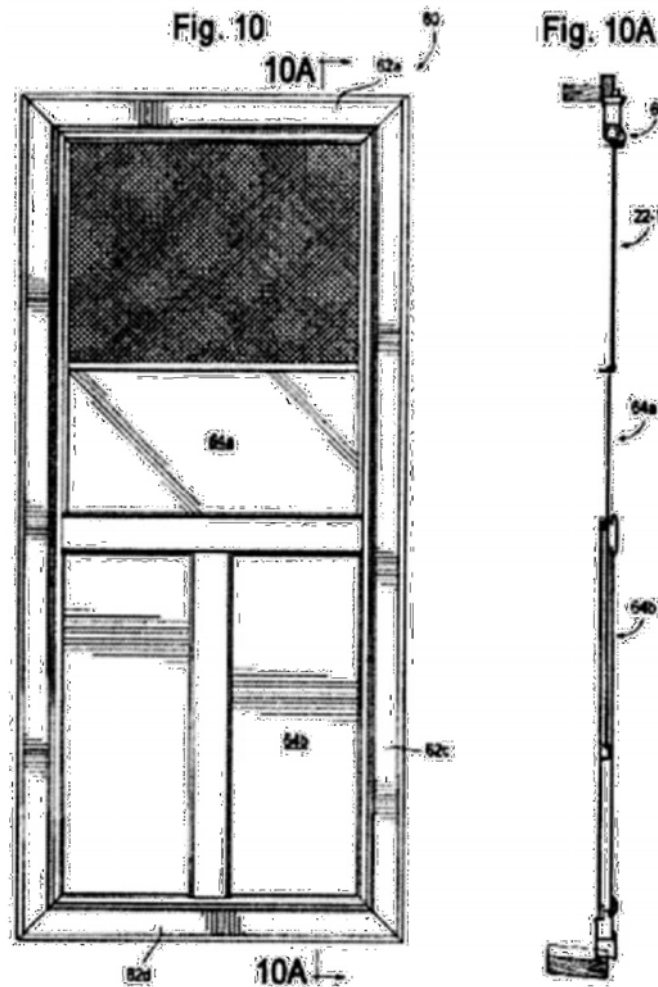

*1323

559 F.3d 1317, 90 U.S.P.Q.2d 1257
(Cite as: 559 F.3d 1317)

Fig. 7B

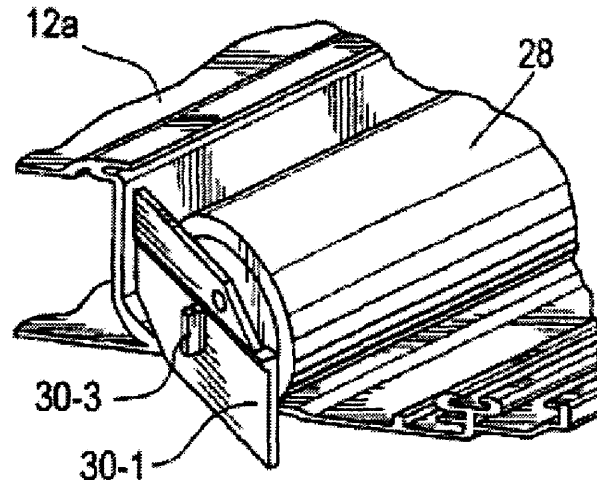

Claim 14 of the patent, which is representative of the claims at issue, states,

A door comprising:

first and second spaced apart jambs, the jambs are connected at one end by a header and at the other end by a sill wherein each jamb carries an axially oriented insert track, and an axially oriented fabric track;

elongated, facing, weather stripping located in each fabric track wherein first and second portions of the weather stripping face one another;

a screen module coupled to the header, the screen module carries a retractable screen having a selected width and having a free end wherein the free end is attached to an elongated feed assembly that extends at least across the width of the screen and which carries an elongated L-shaped connector element;

an insert carried in and movable in the insert tracks wherein the insert is positionable at a plurality of 5 locations along the jambs and wherein the connector element slidably engages an elongated section of the insert whereby as the insert moves toward the sill the screen is extracted from the module and edges of the screen and ends of the elongated feed

assembly slide in the fabric tracks between facing weather stripping portions with the screen retracting into the module as the insert moves toward the header.

Id. col.8 l.55-col.9 l.13.

The '998 patent issued on September 16, 2003. On June 25, 2003, Larson filed a continuation application, No. 10/606,039 (the "039 Continuation"), directed towards similar screen door technology.

II.

Aluminart manufactures storm door products, including a storm door with a retractable screen. On October 24, 2003, Larson filed suit against Aluminart, alleging that its storm door with a retractable screen infringes the '998 patent. Responding to Larson's infringement allegations, Aluminart contended that Larson had engaged in inequitable conduct during the prosecution of the '465 Application. Aluminart also filed a request for reexamination ("Reexam Request") of the '998 patent on September 28, 2004, arguing there *1324 was a substantial new question of patentability based on prior art not considered during prosecution. Aluminart requested reexamination of claims 14-22 of the '998 patent based on [U.S. Patent No. 3,244,222 \(the "Johnson patent"\)](#), which had not been considered by the PTO examiner during prosecution. The district court stayed Larson's lawsuit on October 4, 2004, pending the outcome of the reex-

559 F.3d 1317, 90 U.S.P.Q.2d 1257
(Cite as: 559 F.3d 1317)

amination.

III.

A.

The PTO simultaneously conducted the prosecution of the '039 Continuation and the reexamination of the '998 patent. In both proceedings, Larson was represented by James Patterson, its patent attorney. In September 2004, the examiner issued an office action, rejecting certain claims of the '039 Continuation in view of the Johnson patent ("First Office Action"). Aluminart included the First Office Action in its Reexam Request. On May 3, 2005 ("Second Office Action") and September 21, 2005 ("Third Office Action"), the examiner issued further office actions rejecting claims in view of the Johnson patent, but also in combination with [U.S. Patent No. 6,640,869 \(the "Ralph patent"\)](#) and [U.S. Patent No. 2,107,755 \(the "Kemp patent"\)](#).

On June 23, 2006, after receiving a response from Larson to the Third Office Action, the examiner rejected claims of the '039 Continuation as obvious in view of the Johnson patent and the Kemp patent ("Fourth Office Action"). Although agreeing with Larson that the Johnson patent failed to disclose a "screen and member extending into the screen tracks," the examiner stated that "other prior art, of which [the Kemp patent] is used as an example (see also German 19639478)" showed these same limitations. The German 19639478 Patent (the "DE '478 patent") is an untranslated German patent purportedly showing a screen and window configuration. To date, the '039 Continuation has not issued as a patent and it appears to have become abandoned.

B.

The PTO granted the Reexam Request on December 20, 2004. On February 25, 2005, during the reexamination proceedings, Larson's patent attorney, Mr. Patterson, submitted an Information Disclosure Statement ("IDS") disclosing some 200 patents for review by the Reexamination Panel. In addition, Mr. Patterson submitted several district court pleadings from this litigation, including Aluminart's initial inequitable conduct allegations. He also submitted a supplemental IDS on June 10, 2005, disclosing the co-pending '039 Continuation, the existence of the

Second Office Action in the prosecution of the '039 Continuation, and three additional references cited during the prosecution of the '039 Continuation-[U.S. Patent No. 5,540,476](#), and the Kemp and Ralph patents. However, neither the Third Office Action, the Fourth Office Action, nor the DE '478 patent cited by the examiner in the Fourth Office Action, were ever disclosed to the Reexamination Panel.

On September 13, 2005, the Reexamination Panel rejected claims 1-22 of the '998 patent as being anticipated by the Johnson patent, or obvious in light of the Johnson patent in combination with other prior art references. Responding, Mr. Patterson appeared before the Reexamination Panel and submitted a written amendment, contending that the rejections were incorrect. He argued, among other distinguishing features, that the Johnson patent did not disclose "an elongated feed assembly which slides in the fabric tracks between facing weather stripping." The Reexamination Panel agreed and suggested that the claim rejections in view of Johnson be withdrawn.

*1325 On January 26, 2006, the Reexamination Panel issued a Notice of Intent to Issue Ex Parte Reexamination Certificate, canceling claims 1-10, confirming the patentability of claims 14-20, and allowing claims 11-13, 21, and 22 with slight amendments. The '998 Reexamination Certificate was published on September 19, 2006.

IV.

After the PTO issued the '998 Reexamination Certificate, the district court lifted its stay of proceedings. Subsequently, Aluminart amended its pleadings to include a counterclaim alleging that Larson had engaged in inequitable conduct during the reexamination of the '998 patent. On July 17 and 18, 2007, the district court held a bench trial on Aluminart's inequitable conduct claims. Aluminart argued that Larson withheld several material references from the Reexamination Panel: (1) product and marketing materials for screen configurations produced by a company named Genius (the "Genius Literature"); (2) the DE '478 patent; (3) product and marketing materials for screen configurations produced by a company named Preferred Engineering (the "Preferred Engineering Literature"); and (4) the Third and Fourth Office Actions. Aluminart further argued, based on comparisons with the disclosed prior art and testimony from

559 F.3d 1317, 90 U.S.P.Q.2d 1257
(Cite as: 559 F.3d 1317)

its expert, Dr. Jerry Hall, that the withheld references were not cumulative of prior art already before the Reexamination Panel. Aluminart also argued that this material was withheld with deceptive intent. According to Aluminart, notwithstanding its inability to provide direct evidence, Larson's deceptive intent could be inferred by the number of withheld references and its failure to provide any plausible excuse for its non-disclosure.

In response, Larson asserted that each of the allegedly material references was cumulative of prior art already disclosed to the Reexamination Panel, namely the Johnson and Kemp patents, and [U.S. Patent No. 6,082,432 \(the "Kissinger patent"\)](#). Regarding the Third and Fourth Office Actions, Larson argued that, while these were not disclosed, every critical reference cited in them had been disclosed to the Reexamination Panel. Furthermore, Larson argued that there was no need to disclose the Third and Fourth Office Actions themselves because they both merely contained examiner analysis that was the same as that in previous office actions, which had already been disclosed to the Reexamination Panel. Addressing the issue of intent, Larson focused on the absence of direct evidence, arguing that merely withholding references, without more, could not constitute the requisite intent. Additionally, Larson argued that it had disclosed to the Reexamination Panel the parallel prosecution of the '039 Continuation. This disclosure, it asserted, was evidence of good faith rather than an intent to deceive.

On September 26, 2007, the district court found that Larson had engaged in inequitable conduct before the PTO. Consequently, it held the '998 patent unenforceable. [Inequitable Conduct Decision, 513 F.Supp.2d at 1105](#). Agreeing with Aluminart, the court found that each of the withheld items—the Genius Literature, the Preferred Engineering Literature, the DE '478 patent, and the Third and Fourth Office Actions—were material and not cumulative of prior art already before the Reexamination Panel. [Id. at 1110-16](#). Regarding the three prior art references, the court concluded, based on Dr. Hall's testimony, that each reference disclosed important material that had not been previously provided. [Id. at 1110-15](#). Relying on our decision in [Dayco Products, Inc. v. Total Containment, Inc.](#), 329 F.3d 1358 (Fed.Cir.2003), the court also found that the withheld Third and Fourth Office Actions were material. *1326 [Inequitable](#)

[Conduct Decision, 513 F.Supp.2d at 1114-16](#). In that regard, the court noted that, in addition to providing the examiner's comments about the substantially similar claims of the '039 Continuation, the Fourth Office Action also mentioned the DE '478 patent—which was not disclosed and was found to be material. [Id.](#)

The district court also ruled that Larson had withheld the above material with the requisite intent. [Id. at 1116-17](#). The court agreed with Aluminart, finding that deceptive intent could be inferred from the circumstances. [Id.](#) According to the court, Larson not only failed to disclose several material references, but it also did not provide any plausible excuse for withholding these materials from the PTO. [Id.](#)

Determining that the threshold levels of materiality and intent had been satisfied, the district court balanced these two factors and determined that Larson had engaged in inequitable conduct. [Id. at 1117-18](#). Based on its determinations that each reference was highly material, in conjunction with what it viewed as Larson's implausible arguments relating to cumulativeness and good faith, the district court held that the '998 patent was unenforceable. [Id.](#) The court therefore dismissed Larson's infringement claims.^{FN1}

^{FN1}. At the same time, the court dismissed as moot Aluminart's counterclaims of non-infringement and invalidity.

Arguing that the case was exceptional, Aluminart moved for attorney's fees under [35 U.S.C. § 285](#). In denying the motion, the court noted that not every ruling of inequitable conduct results in an exceptional case determination. [Fees Decision, 529 F.Supp.2d at 1060](#). Additionally, the court noted that Larson alerted the Reexamination Panel to the prosecution of the '039 Continuation and had not made affirmative misrepresentations, both of which the court viewed as weighing against an exceptional case determination. [Id. at 1061](#).

DISCUSSION

Larson appeals the district court's decision that the '998 patent is unenforceable by reason of inequitable conduct. For its part, Aluminart cross-appeals the court's decision that the case was not exceptional under [§ 285](#). We turn first to Larson's appeal.

559 F.3d 1317, 90 U.S.P.Q.2d 1257
(Cite as: 559 F.3d 1317)

I.

[1][2] “A patent may be rendered unenforceable for inequitable conduct if an applicant, with intent to mislead or deceive the examiner, fails to disclose material information or submits materially false information to the PTO during prosecution.” *Digital Control, Inc. v. Charles Mach. Works*, 437 F.3d 1309, 1313 (Fed.Cir.2006). To successfully prove inequitable conduct, “the accused infringer must present ‘evidence that the applicant (1) made an affirmative misrepresentation of material fact, failed to disclose material information, or submitted false material information, and (2) intended to deceive the [PTO].’ ” *Star Scientific, Inc. v. R.J. Reynolds Tobacco Co.*, 537 F.3d 1357, 1365 (Fed.Cir.2008) (quoting *Cargill, Inc. v. Canbra Foods, Ltd.*, 476 F.3d 1359, 1363 (Fed.Cir.2007)). In addition, “at least a threshold level of each element-i.e., both materiality and intent to deceive-must be proven by clear and convincing evidence.” *Star Scientific*, 537 F.3d at 1365.

[3] “[W]e have held that ‘information is material when a reasonable examiner would consider it important in deciding whether to allow the application to issue as a patent.’ ” *1327*Star Scientific*, 537 F.3d at 1367 (quoting *Symantec Corp. v. Computer Assocs. Int'l, Inc.*, 522 F.3d 1279, 1297 (Fed.Cir.2008)). Moreover, “[i]nformation concealed from the PTO may be material even though it would not invalidate the patent.” *Li Second Family Ltd. v. Toshiba Corp.*, 231 F.3d 1373, 1380 (Fed.Cir.2000). However, a withheld otherwise material reference is not material if it is merely cumulative to, or less relevant than, information already considered by the examiner. See *Digital Control*, 437 F.3d at 1319;*Pro-Mold & Tool Co. v. Great Lakes Plastics, Inc.*, 75 F.3d 1568, 1577 (Fed.Cir.1996).

[4] “[I]nequitable conduct requires not intent to withhold, but rather intent to deceive.” <http://www.westlaw.com/Find/Default.wl?rs=dfa1.0&vr=2.0&DB=506&FindType=Y&ReferencePosition-Type=S&SerialNum=2003377036&ReferencePosition=1367>*Dayco Prods.*, 329 F.3d at 1367. “The intent element of the offense is ... in the main proven by inferences drawn from facts, with the col-

lection of inferences permitting a confident judgment that deceit has occurred.” *Akron Polymer Container Corp. v. Exxel Container, Inc.*, 148 F.3d 1380, 1385 (Fed.Cir.1998).

[5] If the requirements of materiality and intent are met, “[t]he court must then determine whether the questioned conduct amounts to inequitable conduct by balancing the levels of materiality and intent, ‘with a greater showing of one factor allowing a lesser showing of the other.’ ” *Digital Control*, 437 F.3d at 1313 (quoting *Union Pac. Res. Co. v. Chesapeake Energy Corp.*, 236 F.3d 684, 693 (Fed.Cir.2001)).

[6][7][8] “When, after a trial, the court has made factual findings as to materiality and deceptive intent, those factual findings are reviewed for clear error, and the decision of the ultimate issue of inequitable conduct is reviewed for abuse of discretion.” *Digital Control*, 437 F.3d at 1313. A factual finding is clearly erroneous “when, ‘although there is evidence to support [the finding], the reviewing court on the entire evidence is left with the definite and firm conviction that a mistake has been committed.’ ” *Tegal Corp. v. Tokyo Electron Am., Inc.*, 257 F.3d 1331, 1338-39 (Fed.Cir.2001) (quoting *United States v. U.S. Gypsum Co.*, 333 U.S. 364, 395, 68 S.Ct. 525, 92 L.Ed. 746 (1948)). An abuse of discretion occurs when (1) the trial court's decision is clearly unreasonable, arbitrary, or fanciful, (2) the court's decision is based on an erroneous construction of the law, (3) the court's factual findings are clearly erroneous, or (4) the record contains no evidence upon which the court rationally could have based its decision. See *W. Elec. Co. v. Piezo Tech., Inc.*, 860 F.2d 428, 430-31 (Fed.Cir.1988).

Larson argues that the district court clearly erred in finding that Aluminart had established by clear and convincing evidence that the Genius Literature, the DE '478 patent, the Preferred Engineering Literature, and the Third and Fourth Office Actions are material. Specifically, Larson contends, as it did before the district court, that the references are cumulative of prior art that was already before the Reexamination Panel, namely the Kissinger and Kemp patents. In addition, Larson contends that the district court clearly erred in finding, without direct evidence, that it intended to deceive the Reexamination Panel. Specifically, according to Larson, the court improperly

559 F.3d 1317, 90 U.S.P.Q.2d 1257
 (Cite as: 559 F.3d 1317)

inferred intent merely because of the nondisclosure of references. Finally, Larson urges that, even if the district court's findings of materiality and intent were correct, the court abused its discretion in balancing the two factors in ultimately ruling that the '998 patent was unenforceable.

II.

A.

[9] We turn first to Larson's failure to disclose to the Reexamination Panel the Genius Literature and the DE '478 patent. We treat these items together because, according to Larson, they both are allegedly*1328 cumulative of the Kissinger patent, which was before the Reexamination Panel.

The Genius Literature is product and marketing material disclosing different sizes and designs of retractable roller insect screen systems, which can be in-

stalled on windows or doors. A rigid frame or "cassette" borders the insect screen. The frame, including the insect screen, inserts into guide rails, which are lined with "brushpile." Once the frame and insect screen are inserted into the guide rails, the insect screen is able to slide up and down or, in other words, retract. The district court found the Genius Literature material because it "discloses a retractable screen assembly containing an elongated member extending into screen tracks and between weather stripping that was advertised for incorporation into a door or window." *Inequitable Conduct Decision*, 513 F.Supp.2d at 1111.

According to the English abstract, the DE '478 patent discloses a meshwork cloth blind that can be pulled from a coiling roller to cover a doorway or window. As shown in figures 4 and 5 of the DE '478 patent below, brushes 60 and 66 engage the cloth blind 2.

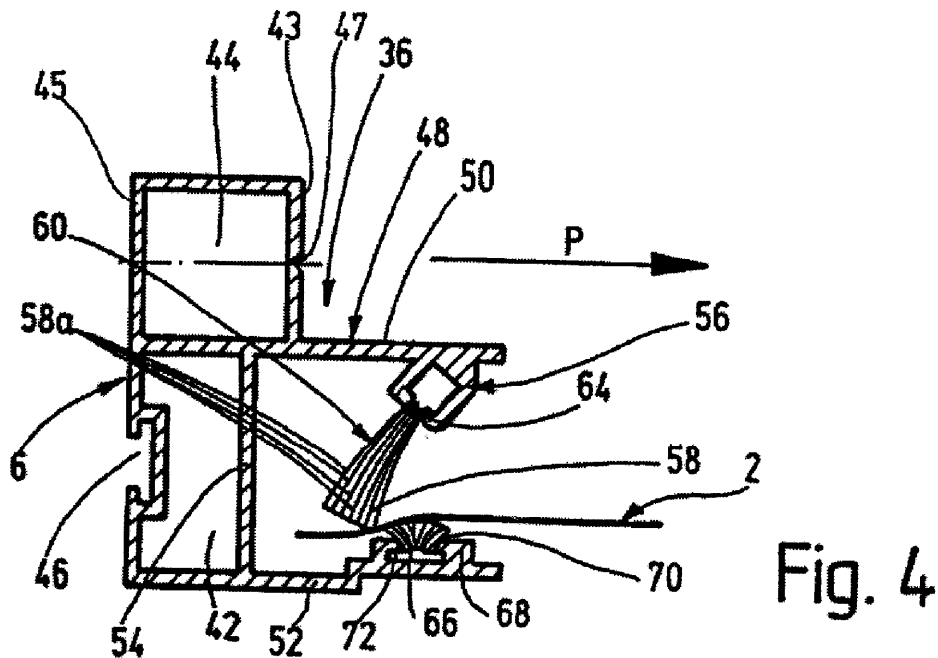

*1329

559 F.3d 1317, 90 U.S.P.Q.2d 1257
(Cite as: 559 F.3d 1317)

because they both disclose weather stripping that maintains continuous contact with a screen, as opposed to the Kissinger patent, which, according to Dr. Hall, only discloses “partial weather stripping.” According to Larson, however, Dr. Hall admitted that partial weather stripping can still be considered “weather stripping.” Concerning the DE '478 patent, Larson further notes that because Dr. Hall could not read the German specification, he admitted that his opinion was based solely on assumptions made from the brush angle in the patent's figures (shown above). Additionally, Larson argues that, regardless of Dr. Hall's weather stripping distinction, weather stripping that maintains continuous contact with a screen was irrelevant to the Reexamination Panel and therefore could not be evidence of materiality. In short, Larson urges that the Kissinger patent discloses the same weather stripping as the Genius Literature and the DE '478 patent.

Aluminart responds that the district court's materiality finding is supported by the Genius Literature and the DE '478 patent as well as Dr. Hall's testimony. Aluminart argues that the district court correctly determined that the Genius Literature and the DE '478

patent are not cumulative of the Kissinger patent. Pointing to Dr. Hall's testimony, Aluminart contends that the Genius Literature and the DE '478 patent show, more clearly and completely than the Kissinger patent, a retractable screen assembly having an elongated member extending into screen tracks and between weather stripping-features that the Reexamination Panel could not find in the prior art. Aluminart also asserts that, as opined by Dr. Hall, the Genius Literature and the DE '478 patent disclose weather stripping with complete retention capability.

The Kissinger patent is directed to “[a] roll-up screen door appliance for drawing a screen panel horizontally across the span of a door frame....” Kissinger patent abstract. The patent describes a “channeled horizontal track 28 for mating engagement with the pull rod 25 to guide the screen panel 15 across the span of the door opening”—i.e., an elongated member extending into screen tracks. *See id.* col.3 ll.35-59; figs. 5, 7.

*1331

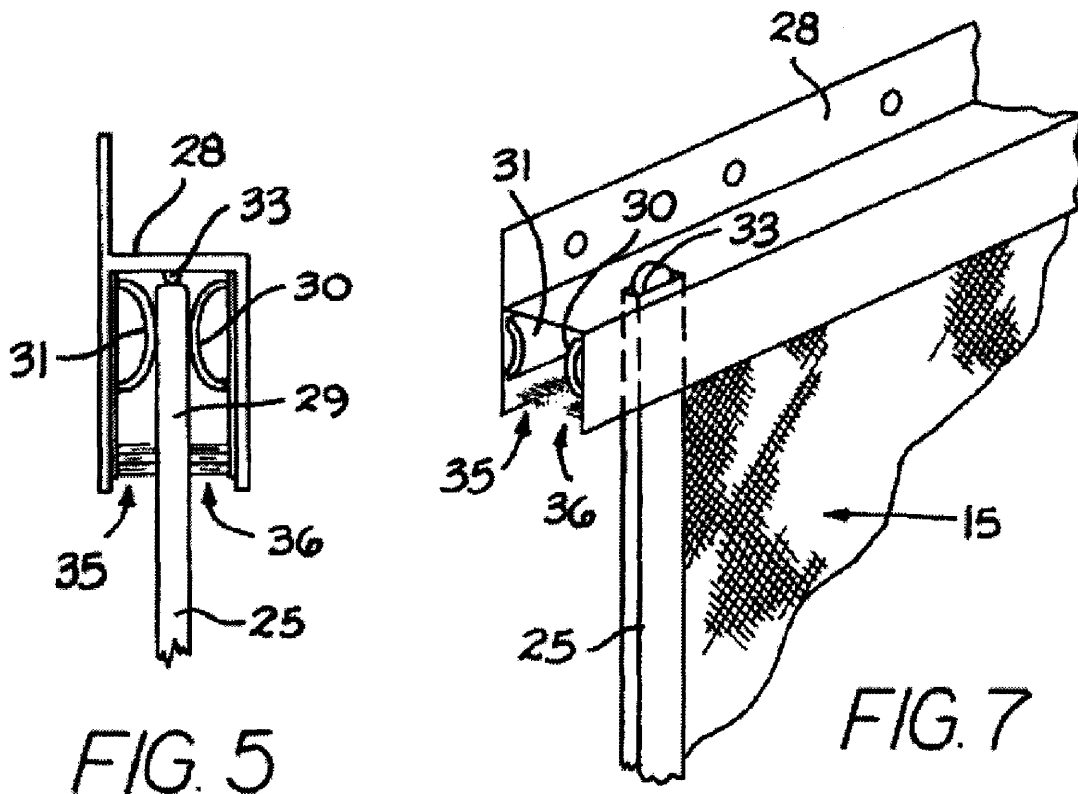

559 F.3d 1317, 90 U.S.P.Q.2d 1257
(Cite as: 559 F.3d 1317)

At the same time, the Kissinger patent discloses the use of weather stripping:

Upper and lower edges of the screen panel **15** are dressed on both sides to present smooth, burrless edges to engage the opposed brushes **35**, **36** extending inwardly from opposite sides of the track **28** sidewalls, **FIGS.5** and **7**. This constitutes insect impeding structure, and is disposed along said horizontal track across the span of the door to keep insects from passing through or around the screen panel in the presence of breezes that would otherwise cause flutter and gapping, and to resist gapping caused by contact with the extended screen surfaces.

Id. col.4 ll.1-10.

We hold that the district court clearly erred in ruling that the Genius Literature and the DE '478 patent are material and not cumulative of the Kissinger patent. As stated by the district court and Aluminart's expert, Dr. Hall, the Genius Literature and the DE '478 patent were found to be material because they disclose an elongated member extending into screen tracks and between weather stripping. [Inequitable Conduct Decision, 513 F.Supp.2d at 1111, 1114](#). As seen above, however, the Kissinger patent, which was already before the Reexamination Panel, discloses these same elements. Specifically, the Kissinger patent shows a pull rod extending into a channeled horizontal track to guide the screen panel-in other words, an elongated member extending into screen tracks. In addition, the Kissinger patent shows that the screen tracks are lined with brushes, or weather stripping. Therefore, even if the Genius Literature and the DE '478 patent do disclose these elements, they are merely cumulative and therefore not material. *See, e.g., Digital Control, 437 F.3d at 1319* (“However, a withheld otherwise material prior art reference is not material for the purposes of inequitable conduct if it is merely cumulative***1332** to that information considered by the examiner.”); [Molins PLC v. Textron, Inc., 48 F.3d 1172, 1185 \(Fed.Cir.2000\)](#) (“[The withheld reference] was no more pertinent to [the patent application at issue] than was claim 26 of the Lemelson '770 patent, which was already of record.... Thus the court's finding that the [withheld reference] was material was clearly erroneous....”); [Litton Indus. Prods. Inc. v. Solid State Sys. Corp., 755 F.2d 158,](#)

[167 \(Fed.Cir.1985\)](#) 2008-1096, 2008-1174 (“Given the cumulative nature of Balamuth '288 compared to Balamuth '674 ... [the] failure to disclose Balamuth '288 to the PTO ... does not reach the threshold level of materiality....”).

Our view is not changed by Dr. Hall's testimony about weather stripping, upon which the district court relied. In testifying that the Genius Literature and the DE '478 patent were more material than, and not cumulative of, the Kissinger patent, Dr. Hall emphasized that the Genius Literature's and the DE '478 patent's weather stripping provides “a retention capability of the screen,” whereas the “brushes” of the Kissinger patent only demonstrate “partial weather stripping.” Trial Tr. 102:1-4; 156:1-5, July 17, 2007. Dr. Hall further testified that the Kissinger patent “doesn't call it weather stripping, it calls it brushes that impede insects.” *Id.* at 162:16-18. Dr. Hall admitted, however, that he did not in fact know whether or not the fiber pile of the Genius Literature is “complete weather stripping” rather than “partial weather stripping”—the very distinction that he opined makes the Genius Literature material and not cumulative. *Id.* at 126:10-24. He further admitted that brushes **35** and **36** in figures 5 and 7 of the Kissinger patent could possibly be considered weather stripping. *Id.* at 151:17-22. In addition, Dr. Hall conceded that neither the Genius Literature nor the Kissinger patent uses the term “weather stripping.” Instead, both disclose similar “fiber pile” brushes. *Id.* at 164:15-19. Regarding the DE '478 patent, Dr. Hall admitted that both the DE '478 and Kissinger patents show the same type of weather stripping for the same primary purpose—brushes to impede insects. *Id.* at 162:6-163:2. In short, we are unable to conclude that Dr. Hall's testimony, upon which the district court relied, supports the finding that the weather stripping shown in the Genius Literature and the DE '478 patent is not cumulative of the brushes described in the Kissinger patent.

Moreover, Dr. Hall's testimony relating to purported greater retention capability of the weather stripping in the Genius Literature and the DE '478 patent was irrelevant to the claim limitations at issue and therefore could not support a finding of materiality and non-cumulativeness. *See, e.g., Regents of the Univ. of Cal. v. Eli Lilly & Co., 119 F.3d 1559, 1575 (Fed.Cir.1997)* (“What is relevant is whether [the withheld material] discloses subject matter relevant

559 F.3d 1317, 90 U.S.P.Q.2d 1257
(Cite as: 559 F.3d 1317)

to the examination of the ... patent application that is not taught by the [material already before the PTO.]”); *Micro Chem., Inc. v. Great Plains Chem. Co.*, 103 F.3d 1538, 1550 (Fed.Cir.1997) (finding withheld reference merely cumulative because patents disclosing the “relevant limitations of the claims” were already before the examiner), *abrogated on other grounds by Pfaff v. Wells Elecs., Inc.*, 525 U.S. 55, 119 S.Ct. 304, 142 L.Ed.2d 261 (1998); *cf. Pro-Mold & Tool*, 75 F.3d at 1577 (concluding that withheld prior art was not material because it failed to show several relevant claim limitations that were disclosed in art already before the PTO); *Litton Indus. Prods.*, 755 F.2d at 167 (reversing the district court's finding that a reference was not cumulative because “[w]hile the precise structural arrangements of the devices disclosed by these references differ, they have the same relative*1333 degree of materiality with respect to the claimed invention”).

The claim language and limitations at issue require neither a specific type of weather stripping nor a particular retention capability. Rather, the limitations that were at issue before the Reexamination Panel simply require any type of general weather stripping. *See, e.g., '998 patent* col.8 ll.62-64 (“weather stripping located in each fabric track wherein first and second portions of the weather stripping face one another”); *id.* col.9 ll.10-13 (“the elongated feed assembly slide in the fabric tracks between facing weather stripping portions with the screen retracting into the module as the insert moves toward the header”). Consequently, because the Reexamination Panel was required to give the claim language its broadest reasonable interpretation, *see, e.g., In re Trans Texas Holdings Corp.*, 498 F.3d 1290, 1298 (Fed.Cir.2007) (“Claims are given ‘their broadest reasonable interpretation, consistent with the specification, in reexamination proceedings.’ ” (quoting *In re Yamamoto*, 740 F.2d 1569, 1571 (Fed.Cir.1984))), the Reexamination Panel was not concerned with a particular retention capability. Accordingly, a greater retention capability of weather stripping was wholly irrelevant-i.e., immaterial-to the Reexamination Panel and could not be the basis of a distinguishing feature to make the Genius Literature and the DE '478 patent not cumulative-i.e., material.^{FN2}

^{FN2}. Even if a greater screen retention capability was relevant, it is not clear that the Kissinger patent does not also describe this

feature. As disclosed in the Kissinger patent, “the pull rod **25** for entering the upper channel [is] frictionally grasped between typically two hollow rubber frictional pad members **30, 31**.” Kissinger patent col.3 ll.53-56; *see also id.* figs. 5, 7. Indeed, these “rubber frictional pads” “retain the screen panel **15** tautly,” thereby seemingly creating a significant retention pressure on the screen. *Id.* col.3 ll.55-57.

Aluminart makes one argument specific to the Genius Literature. It contends that the Genius Literature shows how the elements of the references already before the Reexamination Panel-particularly, the Johnson patent and the Kemp patent-could be used with weather stripping. Accordingly, relying on our decisions in *Cargill* and *Molins PLC*, Aluminart contends that the Genius Literature is material because it discloses a new combination of elements that were only previously known in several, separate references. We are not persuaded by this argument.

Aluminart's reliance on *Cargill* and *Molins PLC* is misplaced. In *Cargill*, we determined that withheld test data was material because it was different from, and not comparable to, other information before the examiner-a fact admitted by the patentee. *See Cargill*, 476 F.3d at 1365-66. Similarly in *Molins PLC*, we determined that withheld prior art was material and not cumulative because it showed a new, different combination-previously not disclosed-of elements before the examiner only in separate references. *See Molins PLC*, 48 F.3d at 1180. In this case, in contrast, the allegedly new combination-an elongated pull bar extending into screen tracks that contain weather stripping-is the same combination that was already before the Reexamination Panel in the Kissinger patent. *Cargill* and *Molins PLC* therefore do not support Aluminart's position.

For the foregoing reasons, we hold that the district court clearly erred in finding the Genius Literature and the DE '478 patent not cumulative of prior art that was already before the Reexamination Panel. We therefore reverse the finding that the Genius Literature and the DE '478 patent were material.

*1334 B.

[10] We turn next to Larson's failure to disclose the

559 F.3d 1317, 90 U.S.P.Q.2d 1257
(Cite as: 559 F.3d 1317)

Preferred Engineering Literature to the Reexamination Panel. Similar to the Genius Literature, the Preferred Engineering Literature consists of product and instructive material for a “self-storing window screen” made by Preferred Engineering. Pertinent to this case, the Preferred Engineering Literature describes a window frame assembly that secures a retractable mesh screen. One end of the mesh screen is attached to a “roll tube,” which the mesh screen is housed in and rolls-up into. A “pull rail” is attached to the opposite end of the mesh screen, providing a handle to pull the mesh screen out of the “roll tube.” The “roll tube,” including the mesh screen that it houses, is attached to one side of the frame. When the mesh screen is rolled into and out of the “roll tube,” the remaining two sides of the mesh screen-not attached to either the “roll tube” or the “pull rail”-travel in rails in the frame.

Relying upon the testimony of Dr. Hall, the district court found the Preferred Engineering Literature material because it discloses a “pull bar in channels and shows that the screen would be sliding in the channels.” [Inequitable Conduct Decision, 513 F.Supp.2d at 1112](#). In addition, the court found significant the fact that the Preferred Engineering Literature could be easily modified to attach a glass insert, despite failing to explicitly disclose this ability. *Id.*

On appeal, Larson challenges the court's finding. It argues that the Kemp patent, which was already before the Reexamination Panel, discloses these same elements. Larson also argues that the Kemp patent discloses a screen that is attachable to glass-an element that is not present in the Preferred Engineering Literature.

Aluminart argues that the district court's materiality finding regarding the Preferred Engineering literature is supported by the trial evidence, such as the literature itself and trial testimony. According to Aluminart, Dr. Hall testified that the Preferred Engineering literature was clearer than the Kemp patent, and an Aluminart employee, Mr. Frank Raponi, testified that only a slight modification of the Preferred Engineering product was necessary to attach a glass insert. According to Aluminart, the ease with which the Pre-

ferred Engineering product could be modified to include a glass insert is additional evidence that it is not cumulative of the Kemp patent.

As seen, relying on the testimony of Dr. Hall, the district court found that the Preferred Engineering Literature is material because it shows “a pull bar in channels and that the screen would be sliding in the channels.” *Id.* The Kemp patent, which was before the Reexamination Panel, discloses each of these features, however. Thus, regardless of whether the Preferred Engineering Literature discloses these features, it is nonetheless cumulative of prior art already before the PTO. *See, e.g., Digital Control, 437 F.3d at 1319* (“However, a withheld otherwise material prior art reference is not material for the purposes of inequitable conduct if it is merely cumulative to that information considered by the examiner.”).

As suggested by Larson, the Kemp patent shows the same elements that the district court found material in the Preferred Engineering Literature-a pull bar in channels, with a screen sliding in the channels. The invention claimed in the Kemp patent “relates to roll screens of the type employed in residences and other structures for the purpose of preventing insects from entering through opened win*1335 dows...” Kemp patent col.1 ll.1-4. Referring to figure 1, the patent states that

a window frame is indicated at **20** which encompasses the windows indicated generally at **21** and **22** respectively each of which includes a sash **24** and a glass **26**. The frame **20** includes the usual sill **27**. The ... windows are vertically slidable in the frame in accordance with conventional practice. A roll screen formed in accordance with the present invention is shown as including a roller housing **28** secured to the window sill **27** inside of the window **21**, guide members **30**, one fixed to each side of the window opening in the frame **20**, a flexible screen **32** removably secured at one end ... and adapted to be rolled upon or unrolled from a suitable roller within housing **28**....

559 F.3d 1317, 90 U.S.P.Q.2d 1257
(Cite as: 559 F.3d 1317)

ready before the Reexamination Panel. [FN3](#)

[FN3](#). Furthermore, the court acknowledged that neither the Preferred Engineering Literature nor the Kemp patent disclose using weather stripping. *Inequitable Conduct Decision*, 513 F.Supp.2d at 1113. As described above, however, the Kissinger patent does disclose weather stripping, in addition to the combination of other limitations at issue. *See supra* Section II.A. The Preferred Engineering Literature, therefore, is less relevant than, and cumulative of, the Kissinger patent as well. *See, e.g., Mentor H/S*, 244 F.3d at 1378 (affirming cumulateness finding because art already disclosed was “more material in at least one respect”).

Although the district court acknowledged that the Preferred Engineering Literature did not disclose the ability to attach a glass insert, the court nonetheless found support for materiality because, according to Mr. Raponi, the products described in the literature could be easily modified to attach a glass insert. *Inequitable Conduct Decision*, 513 F.Supp.2d at 1113. As admitted on several occasions by Dr. Hall, however, the Kemp patent explicitly discloses this same feature, further suggesting it is more material than the Preferred Engineering Literature. Kemp patent pg. 2 col.1 ll.1-19; *see, e.g., Mentor H/S*, 244 F.3d at 1378 (concluding that prior art already disclosed to the PTO was more material because it disclosed relevant features not present in the withheld reference). When testifying concerning the Genius Literature, Dr. Hall stated as follows:

Q. Dr. Hall, does the Genius literature you reviewed show the retractable screen connected to a sliding piece of glass?

A. It does not.

Q. Now does that in your opinion make the Genius literature not material to the reexam panel in its consideration of the '998 claim?

A. Absolutely not, *because the reexam panel already had windows connected to screens in both the Johnson and Kemp patents, so they didn't need to see that any more....*

Trial Tr. 102:5-15 (emphasis added); *see also id.* at 110:16-23 (“That’s already been demonstrated in the Johnson and the Kemp patents.”); *id.* at 134:6-135:2 (“[B]ut that particular item had been previously taught in Johnson and Kemp, so it didn’t have to be taught in that literature.”). In fact, Dr. Hall not only admitted several times that the Kemp patent discloses the ability to attach a glass insert, but he also repeatedly emphasized that attaching a *1337 glass insert to a pull bar was well known: “You can connect that pull bar to anything, or adopt a sliding window or a sliding panel of any sort”; “Every pull bar can be adapted to be an elongated attachment member”; and “[T]he pull bar can be an attachment, it can be attached to anything.” *Id.* at 110:112-23; 134:6-135:2. Considering the Kemp patent discloses all of the relevant elements-including the ability to attach a glass insert to a pull bar-the fact that the Preferred Engineer product could be easily modified to attach a glass insert adds no value to its alleged materiality and supports the proposition that it is cumulative.

For the foregoing reasons, we hold that the district court clearly erred in finding the Preferred Engineering Literature not cumulative of prior art that was already before the Reexamination Panel. We therefore reverse the finding that the Preferred Engineering Literature was material.

C.

[\[11\]](#) We now come to Larson’s failure to disclose to the Reexamination Panel the Third and Fourth Office Actions from the '039 Continuation. As noted above, both the Third and Fourth Office Actions contained PTO examiner rejections and analysis concerning claims similar to those in the '998 patent’s reexamination. In addition, the Fourth Office Action cited the DE ' 478 patent. Larson first points out that the '039 Continuation’s First Office Action was used as the basis for the Reexamination Request, and that the Second Office Action was explicitly referenced in an IDS submitted to the Reexamination Panel. Under these circumstances, Larson argues, despite not having the subsequent Third and Fourth Office Actions before it, the Reexamination Panel was aware of the simultaneous proceedings before the PTO and the possibility of future office actions in the '039 Continuation. Larson further argues that it disclosed each material reference cited in the Third and Fourth Of-

559 F.3d 1317, 90 U.S.P.Q.2d 1257
(Cite as: 559 F.3d 1317)

office Actions. Although the Fourth Office Action revealed the DE '478 patent for the first time, Larson contends that the examiner merely mentioned the DE '478 patent as an example of art already before the Reexamination Panel.

Larson acknowledges that the Third and Fourth Office Actions both contained examiner comments and rejections. It argues, though, that the examiner provided only summary rejections without meaningful analysis. According to Larson, in the Third and Fourth Office Actions, the examiner articulated rejections almost identical to the previous office actions; mostly discussed the Johnson patent, which had been thoroughly explained in previous office actions; and focused on claim limitations that were not at issue. In other words, Larson contends, because the Third and Fourth Office Actions did not contain examiner comments different from previous office actions and because Larson disclosed all of the material references discussed in those actions, the office actions themselves were not material.

Relying on [Dayco Products](#), Aluminart responds that Larson fails to recognize that it is not only the references cited in the office actions that are important, but also the substance of the examiner's comments. According to Aluminart, the Third and Fourth Office Actions contained remarks that are inconsistent with Larson's arguments to the Reexamination Panel. Specifically, in the Third Office Action, the examiner rejected the claims at issue because the Johnson patent allegedly discloses a screen that extends into tracks. Subsequently, Larson argued the exact opposite position to the Reexamination Panel—that the Johnson patent does not show this feature. In addition, Aluminart argues that the examiner in the Fourth Office Action, despite conceding that the *1338 Johnson patent does not disclose a screen that extends into tracks, articulated a new rejection based on the Johnson and Kemp patents, stating for the first time that the Kemp patent discloses this feature.

We agree with Aluminart on this point. Because the Third and Fourth Office Actions contained another examiner's adverse decisions about substantially similar claims, and because the Third and Fourth Office Actions are not cumulative to the First and Second Office Actions, the district court correctly found the withheld Office Actions material. In [Dayco Products](#), the patentee failed to disclose rejections in

a copending application of claims “that were substantially similar in content and scope to claims pending in the applications that issued as the patents-in-suit.” [329 F.3d at 1367](#). We held “that a contrary decision of another examiner reviewing a substantially similar claim” was material. [Id. at 1368](#). We further explained that, because a “rejection of a substantially similar claim refutes, or is inconsistent with the position that those claims are patentable, [the] adverse decision by another examiner ... meets the materiality standard.” [Id.](#)

It is undisputed that the claims of the '039 Continuation and the ['998 patent](#) have similar content and scope, and that the Third and Fourth Office Actions contained another examiner's rejections. Indeed, Larson does not argue that the claims are not substantially similar or that the '039 Continuation office actions do not contain contrary statements from an examiner. Rather, Larson posits that it disclosed each material reference disclosed in the office actions and that the examiner's rejections were only boilerplate reiterations of previous rejections. Larson's arguments are unpersuasive, however, because they disregard the proposition that “knowledge of a potentially different interpretation is clearly information that an examiner could consider important when examining an application.” [Id.](#)

Indeed, although previous office actions used the Johnson patent to reject the similar claims of the '039 Continuation, the Third Office Action explicitly explained, for the first time, that the Johnson patent shows “the screen is attached ‘across its width’... to the coupling element ... thereby indicating that such extends into the tracks.” This was the first time that the examiner of the '039 Continuation conveyed such specific explanation about the Johnson patent in connection with the “extending into screen tracks” limitation. After receiving the Third Office Action containing this explanation, Larson did not disclose it. Rather, contrary to the '039 Continuation's examiner's view, Larson contended to the Reexamination Panel that the Johnson patent *did not* show a screen extending into tracks. We acknowledge that the '039 Continuation examiner later withdrew his rejection based upon the Johnson patent and came to the same ultimate conclusion as the Reexamination Panel—that the Johnson patent *did not* disclose the “extending into screen tracks” limitation. The '039 Continuation examiner's later view, however, does not change the

559 F.3d 1317, 90 U.S.P.Q.2d 1257
(Cite as: 559 F.3d 1317)

fact that the Third Office Action contained valuable reasoning and rejections at the time when it was made.^{FN4} Importantly, *1339 during the time from when the Third Office Action issued to the time when the Fourth Office Action withdrew the pertinent rejection—more than a year—there was an adverse decision by another examiner that refuted, or was inconsistent with, the position that claim limitations of the '998 patent were patentable over the Johnson patent. Accordingly, the Third Office Action was material.

FN4. We do not find the Third Office Action material because of Larson's attorney arguments to the Reexamination Panel, which were contrary to the '039 Continuation examiner's interpretations in the Third Office Action. Cf. Line Rothman & Glamourmom LLC v. Target Corp., No.2008-1375, 2009 WL 349474, at *15 (Fed.Cir. Feb. 13, 2009) (“While the law prohibits genuine misrepresentations of material fact, a prosecuting attorney is free to present argument in favor of patentability without fear of committing inequitable conduct.”); Young v. Lumenis, Inc., 492 F.3d 1336, 1349 (Fed.Cir.2007) (arguing contrary to an examiner's rejection and attempting to distinguish the claims from the prior art were not affirmative misrepresentations of material fact). Rather, as explained, the Third Office Action was material because it contained an interpretation and adverse decision by another examiner that refuted the patentability of the claim limitations of the '998 patent.

The Fourth Office Action articulated a new rejection of the “extending into screen tracks” limitation in view of the Johnson and Kemp patents. Specifically, in the Fourth Office Action, the examiner found for the first time that the Kemp patent shows a “screen end member actually being located in a screen track.” Furthermore, the examiner explained in the Fourth Office Action that a “screen end member extending into the screen tracks” was readily known in the prior art, and not just shown in the Kemp patent. Significantly, the Reexamination Panel, despite thoroughly analyzing the Kemp patent, as well as other prior art, failed to come to the same conclusion that the “screen end member extending into the screen tracks” limitation was disclosed in the Kemp patent or other prior art. Under these circumstances, the adverse decision

of the examiner in the '039 Continuation, based on a different explanation and interpretation of the Kemp patent and other prior art, was “clearly information that an examiner could consider important.” <http://www.westlaw.com/Find/Default.wl?rs=dfa1.0&vr=2.0&DB=506&FindType=Y&ReferencePosition-Type=S&SerialNum=2003377036&ReferencePosition=1368>*Dayco*, 329 F.3d at 1368.

For the foregoing reasons, we hold that the district court did not err in finding the Third and Fourth Office Actions not cumulative and material.^{FN5}

FN5. There is nothing in the record presented to us indicating that the Reexamination Panel was independently aware of the Third and Fourth Office Actions. We, therefore, need not consider whether Larson would have had a duty to disclose the office actions under those circumstances. Cf. Litton Sys., Inc. v. Honeywell, Inc., 87 F.3d 1559, 1571 (Fed.Cir.1996) (“An applicant cannot [be deemed to have] intentionally with [eld] a reference actually considered by the PTO, even though the applicant may not have disclosed the art.”), *vacated on other grounds by* 520 U.S. 1111, 117 S.Ct. 1240, 137 L.Ed.2d 323 (1997); Molins PLC, 48 F.3d at 1185 (same).

III.

We now turn to the district court's finding that, in failing to disclose the Genius Literature, the DE '478 patent, the Preferred Engineering Literature, and the Third and Fourth Office Actions to the Reexamination Panel, Larson acted with deceptive intent. In concluding that the clear and convincing threshold had been satisfied, the court largely inferred deceptive intent based on Larson's failure to disclose all of the above five items to the Reexamination Panel, in conjunction with its failure to provide any explanation for its nondisclosure. Inequitable Conduct Decision, 513 F.Supp.2d at 1117. However, because we today hold that three of these five items—the Genius Literature, the DE '478 patent, and the Preferred Engineering Literature—are not material, the district court's finding of deceptive intent cannot stand. See, e.g., Digital Control, 437 F.3d at 1311 (“As the dis-

559 F.3d 1317, 90 U.S.P.Q.2d 1257
(Cite as: 559 F.3d 1317)

district court's determination of inequitable conduct was premised on the materiality of both the misstatements in the Rule 131 declaration and the failure to disclose prior art, we must vacate the district court's determination that the patents were unenforceable for inequitable conduct and remand for further proceedings.”); *1340 *id.* at 1321 (“[W]e cannot tell how heavily the district court relied upon the [improper finding of] materiality of the omission of the Rorden patent when assessing Dr. Mercer's credibility and when determining that the misstatements in the Rule 131 declaration were made with intent to deceive the PTO.”); *Eli Lilly*, 119 F.3d at 1575 (“Because we conclude that the district court's finding of materiality was clearly erroneous, we also necessarily conclude that the district court clearly erred in inferring deceptive intent....”). We therefore vacate the court's deceptive intent finding and, consequently, its ultimate determination of inequitable conduct. *See, e.g., Purdue Pharma L.P. v. Endo Pharmas. Inc.*, 438 F.3d 1123, 1135 (Fed.Cir.2006) (vacating unenforceability because the deceptive intent finding was clearly erroneous and remanding “to give the trial court an opportunity to reconsider its intent finding”); *Molins PLC*, 48 F.3d at 1184 (finding of deceptive intent was “clearly erroneous, and the determination that the method of disclosure constituted inequitable conduct cannot be sustained”). We remand the case to the district court for determination of whether Larson withheld the only remaining material items—the Third and Fourth Office Actions—with a threshold level of deceptive intent and, if so, whether balancing that level of intent with the level of materiality warrants holding the ‘998 patent unenforceable.

IV.

Although the issue is not presently before us, we believe that, in the interest of judicial economy, it is appropriate for us to give some guidance to the district court with respect to the issue of deceptive intent. *See, e.g., Hansen Bancorp, Inc. v. United States*, 367 F.3d 1297, 1314 (Fed.Cir.2004) (giving guidance is appropriate for the “benefit of the parties and the trial court”); *Rumsfeld v. Applied Companies, Inc.*, 325 F.3d 1328, 1335 (Fed.Cir.2003) (“The Board's statements regarding quantum suggest that it is appropriate for us to provide guidance regarding the proper measure of Applied's recovery.”).

First, on remand, it will not be necessary for the dis-

trict court to accept additional evidence. Rather, the court should analyze all of the evidence of record, consistent with this opinion, and determine if Larson withheld the Third and Fourth Office actions with an intent to deceive the PTO.

[12][13][14] Second, materiality does not presume intent, and nondisclosure, by itself, cannot satisfy the deceptive intent element. *See, e.g., Star Scientific*, 537 F.3d at 1366; *M. Eagles Tool Warehouse, Inc. v. Fisher Tooling Co.*, 439 F.3d 1335, 1340 (Fed.Cir.2006); *see also Praxair, Inc. v. ATMI, Inc.*, 543 F.3d 1306, 1313 (Fed.Cir.2008) (“[A] showing of materiality alone does not give rise to a presumption of intent to deceive.”). Rather, the alleged infringer must prove by clear and convincing evidence a specific intent to deceive the PTO. *See Star Scientific*, 537 F.3d at 1366; *see also Kingsdown Med. Consultants v. Hollister, Inc.*, 863 F.2d 867, 876 (Fed.Cir.1988) (en banc in relevant part) (holding even “gross negligence” does not of itself justify an inference of intent to deceive”). While deceptive intent can be inferred from circumstantial evidence, the circumstantial evidence must still be clear and convincing. *Star Scientific*, 537 F.3d at 1366. “Further, the inference must not only be based on sufficient evidence and be reasonable in light of that evidence, but it must also be the single most reasonable inference able to be drawn from the evidence to meet the clear and convincing standard.” *Id.* Relatedly, just as merely withholding a reference cannot support an inference of deceptive intent, *see Dayco Prods.*, 329 F.3d at 1367 (“Intent to deceive cannot be inferred simply from the *1341 decision to withhold the reference where the reasons given for the withholding are plausible.”), so too an accused infringer cannot carry its threshold burden simply by pointing to the absence of a credible good faith explanation. *Star Scientific*, 537 F.3d at 1368; *see M. Eagles Tool Warehouse*, 439 F.3d at 1341 (“When the absence of a good faith explanation is the only evidence of intent, however, that evidence alone does not constitute clear and convincing evidence warranting an inference of intent.”).

Third, on remand, the district court should take into account any evidence of good faith, which militates against a finding of deceptive intent. *See, e.g., Purdue Pharma*, 438 F.3d at 1134; *N. Telecom, Inc. v. Datapoint Corp.*, 908 F.2d 931, 939 (Fed.Cir.1990). However, while the court must consider any such

559 F.3d 1317, 90 U.S.P.Q.2d 1257
(Cite as: 559 F.3d 1317)

evidence provided, the patentee is not required to offer evidence of good faith unless the accused infringer first meets its burden to prove-by clear and convincing evidence-the threshold level of deceptive intent. *See Star Scientific, 537 F.3d at 1368*. In that regard, we note that, on remand, the district court should consider that Larson notified the Reexamination Panel of the simultaneous prosecution of the '039 Continuation, and “thus put the PTO on notice of copendency.” *Akron Polymer Container, 148 F.3d at 1383-84*; *see Dayco Prods., 329 F.3d at 1366* (“[M]embers of the family of applications that issued as the patents-in-suit were disclosed to the examiner assigned to the copending application,” which pointed “away from an intent to deceive.”). The court also should consider the fact that Larson disclosed several pleadings from this lawsuit-including Aluminart's initial allegations of inequitable conduct-and that there was a Second Office Action issued in the '039 Continuation proceedings. Despite Larson's failure to expressly notify the Reexamination Panel of the Third and Fourth Office Actions, the court should consider whether its disclosure to the Reexamination Panel of the parallel proceedings, nevertheless, points away from deceptive intent and must be given weight. *See Akron Polymer Container, 148 F.3d at 1383-84* (“Exxel contends, we think convincingly, that it hardly could be seeking to deceive the PTO as to the existence of copending applications when it actually disclosed the fact of copendency to the Venus examiner.”).

If the district court satisfies itself-in light of all the evidence and consistent with our materiality findings-that Aluminart has established a threshold level of intent by clear and convincing evidence, it will then be required to balance the levels of materiality and intent to determine if a finding of inequitable conduct is warranted. *Star Scientific, 537 F.3d at 1367* (balancing requires a determination of “whether the applicant's conduct before the PTO was egregious enough to warrant holding the entire patent unenforceable”). At that point, the court must balance the *substance* of those threshold levels-with a higher level of materiality permitting a lower level of intent, and vice versa. *Id.* Indeed, some references may be highly material, while others may only be minimally material. *See, e.g., Kemin Foods, L.C. v. Pigmentos Vegetales, 464 F.3d 1339, 1345-46 (Fed.Cir.2006)* (affirming the district court's finding on the “level of materiality” that a withheld reference was not “highly material”); *Purdue Pharma, 438 F.3d at 1133* (“Th[e]

omission of information was material, but not as material as an affirmative misrepresentation....”). In that regard, while we agree with the district court that the Third and Fourth Office Actions are material, the court based its finding of a high level of materiality, at least in part, on the fact that Fourth Office Action revealed the DE '478 patent. On remand, the court should take into account that the DE '478 patent is not *1342 material and whether or not that impacts the level of materiality of the Fourth Office Action.

V.

Finally, although the district court held the '998 patent unenforceable, it declined to find this case exceptional and therefore did not award Aluminart attorney's fees. *Fees Decision, 529 F.Supp.2d at 1060-61*. Aluminart has cross-appealed that decision, contending that the district court clearly erred in failing to find clear and convincing evidence of an exceptional case. However, because we have vacated the finding of inequitable conduct, Aluminart's cross-appeal is now moot. *See, e.g., Hewlett-Packard Co. v. Bausch & Lomb, Inc., 882 F.2d 1556, 1563 n. 6 (Fed.Cir.1989)* (vacating inequitable conduct holding rendered cross-appeal on attorney's fees moot). Consequently, we also vacate the district court's *Fees Decision*. *See, e.g., id. at 1569-70* (mooting the cross-appeal on attorney's fees consequently vacated the district court's order on attorney's fees).

CONCLUSION

In sum, we affirm the district court's holding that the Third and Fourth Office Actions are material. However, we reverse the court's holding that the Genius Literature, the DE '478 patent, and the Preferred Engineering Literature were not cumulative of prior art already before the Reexamination Panel and therefore were material. Because we have reversed the district court's finding that the Genius Literature, the DE '478 patent, and the Preferred Engineering Literature were noncumulative and material, we vacate the court's finding of deceptive intent and, consequently, its ultimate determination that the '998 patent is unenforceable due to inequitable conduct. We remand the case to the district court for further proceedings consistent with this opinion, as set forth above. Specifically, the district court should determine whether Larson acted with deceptive intent when it failed to disclose the Third and Fourth Office Actions to the

559 F.3d 1317, 90 U.S.P.Q.2d 1257
(Cite as: 559 F.3d 1317)

Reexamination Panel. If the court finds that Larson acted with deceptive intent, it should then balance materiality and intent in order to decide whether the ['998 patent](#) should be held unenforceable. Finally, because we have vacated the district court's finding of inequitable conduct, Aluminart's cross-appeal is moot. We vacate the court's *Fees Decision* as moot.

COSTS

Each party shall bear its own costs.

AFFIRMED-IN-PART, REVERSED-IN-PART, VACATED-IN-PART, and REMANDED.

Concurring opinion filed by Circuit Judge [LINN, LINN](#), Circuit Judge, concurring.

I join the opinion of the court, because our precedent so requires. I write separately, however, to express my view that this precedent has significantly diverged from the Supreme Court's treatment of inequitable conduct and perpetuates what was once referred to as a "plague" that our en banc court sought to cure in [Kingsdown Medical Consultants, Ltd. v. Hollister Inc.](#), 863 F.2d 867, 876 n. 15 (Fed.Cir.1988) (en banc) (quoting [Burlington Indus., Inc. v. Dayco Corp.](#), 849 F.2d 1418, 1422 (Fed.Cir.1988) ("[T]he habit of charging inequitable conduct in almost every major patent case has become an absolute plague.")).

Symptoms of this plague are apparent from the facts of this case. The patent-in-suit has undergone examination twice in the PTO, and the patentee has been accused of inequitable conduct on each occasion for allegedly withholding material information. During original prosecution, the PTO considered 143 references, 135 of which the patentee itself had submitted. *1343 When the patent was later asserted in litigation, the accused infringer responded by alleging inequitable conduct. It also initiated reexamination of the patent, which stayed the litigation. With all parties' eyes on the reexamination, the patentee submitted an *additional* 210 references with its first information disclosure statement ("IDS"), including a copy of the competitor's inequitable conduct allegations. The patentee then alerted the PTO to rejections in a co-pending application and submitted two more IDSs in the reexamination, each within approximately one month of the application's Office Actions. The IDSs contained all references relied on in those rejections but did not include the Office Actions

themselves. With full knowledge of the co-pending application, the PTO confirmed the patent, which survived reexamination without substantive change to the litigated claims. When the litigation resumed, the accused infringer again charged the patentee with inequitable conduct, this time based on conduct in the reexamination. This second inequitable conduct allegation was the sole issue at trial. Following remand today, the litigation will continue to focus on inequitable conduct, to the exclusion of the patentee's infringement contentions.

The ease with which inequitable conduct can be pled, but not dismissed, is a problem of our own making. The Supreme Court's three inequitable conduct cases involved overt fraud, not equivocal acts of omission. [Precision Instrument Mfg. Co. v. Auto. Maint. Mach. Co.](#), 324 U.S. 806, 809, 819, 65 S.Ct. 993, 89 L.Ed. 1381 (1945) ("patent claims infected with fraud and perjury" where assignee knew that its employee "gave false dates as to the conception, disclosure, drawing, description and reduction to practice" during interference proceeding and then "secured the perjured ... application and exacted promises from the other parties never to question the validity of any patent that might be issued on that application"); [Keystone Driller Co. v. Gen. Excavator Co.](#), 290 U.S. 240, 243, 54 S.Ct. 146, 78 L.Ed. 293 (1933) (false affidavits and deposition testimonies obtained "for valuable considerations" averring that the prior art use "was an abandoned experiment" and "to keep secret the details of the prior use"); [Hazel-Atlas Glass Co. v. Hartford-Empire Co.](#), 322 U.S. 238, 240, 243, 64 S.Ct. 997, 88 L.Ed. 1250 (1944) (false trade article procured from "an ostensibly disinterested expert" in exchange for \$8,000 to gain patent issuance in spite of previously "insurmountable Patent Office opposition"), *overruled on other grounds by* [Standard Oil Co. v. United States](#), 429 U.S. 17, 97 S.Ct. 31, 50 L.Ed.2d 21 (1976).

We clarified en banc that the "two elements, materiality and intent, must be proven by clear and convincing evidence," and that "'gross negligence' does not of itself justify an inference of intent to deceive." [Kingsdown](#), 863 F.2d at 872, 876. But in seeming contradiction with [Kingsdown](#), a standard even lower than "gross negligence" has propagated through our case law. This standard permits an inference of deceptive intent when "(1) highly material information is withheld; (2) 'the applicant knew of the informa-

559 F.3d 1317, 90 U.S.P.Q.2d 1257
(Cite as: 559 F.3d 1317)

tion [and] ... knew or should have known of the materiality of the information; and (3) the applicant has not provided a credible explanation for the withholding.’ ” *Praxair, Inc. v. ATMI, Inc.*, 543 F.3d 1306, 1313-14 (Fed.Cir.2008) (alterations in original) (quoting *Ferring B.V. v. Barr Labs., Inc.*, 437 F.3d 1181, 1191 (Fed.Cir.2006)) (citing *Pfizer, Inc. v. Teva Pharms. USA, Inc.*, 518 F.3d 1353, 1367 (Fed.Cir.2008); *Critikon, Inc. v. Becton Dickinson Vascular Access, Inc.*, 120 F.3d 1253, 1257 (Fed.Cir.1997)).

This test is problematic. First, the “high materiality” prong of the intent element simply repeats the materiality element.*1344 Conflating materiality and intent in this manner is inconsistent with the principle that “materiality does not presume intent, which is a separate and essential component of inequitable conduct.” *Manville Sales Corp. v. Paramount Sys., Inc.*, 917 F.2d 544, 552 (Fed.Cir.1990) (quoting *Allen Organ Co. v. Kimball Int'l, Inc.*, 839 F.2d 1556, 1567 (Fed.Cir.1988)). The second, “should have known” prong sets forth a simple negligence standard, lower even than the “gross negligence” standard that was expressly rejected in *Kingsdown*.^{FN1} I also question whether a fact-finder who has deemed information to be “highly material” would not also be compelled to conclude that a reasonable patentee “should have known of the materiality,” at least when the patentee “knew of the information,” as prong two requires. Third, the “credible explanation” prong effectively shifts the burden to the patentee to prove a negative: that it did not intend to deceive the PTO. But it is the “accused infringer”—not the patentee—who “must prove by clear and convincing evidence that the material information was withheld with the specific intent to deceive the PTO.” *Star Scientific, Inc. v. R.J. Reynolds Tobacco Co.*, 537 F.3d 1357, 1366 (Fed.Cir.2008). As to this third prong, we have also explained that “[t]he patentee need not offer any good faith explanation unless the accused infringer first carried his burden to prove a *threshold level* of intent to deceive by clear and convincing evidence.” *Id.* at 1368 (emphasis added). As explained above, however, the first two prongs are not evidence of deceptive intent. The first is evidence of materiality; the second is evidence of negligence. These two prongs are therefore insufficient as a matter of law to establish a clear and convincing “threshold level” of deceptive intent before the third prong can ever properly come into play.

^{FN1}. The source of this divergence can be traced to *Critikon*, 120 F.3d at 1256 (citing *Driscoll v. Cebalo*, 731 F.2d 878, 885 (Fed.Cir.1984)). It relied on the pre-*Kingsdown* “should have known” standard of *Driscoll v. Cebalo*, a case explicitly overruled by *Kingsdown* on the issue of gross negligence, 863 F.2d at 876. See Lynn C. Tyler, *Kingsdown Fifteen Years Later: What Does It Take to Prove Inequitable Conduct?*, 13 Fed. Cir. B.J. 267, 276-83 (2004) (collecting panel decisions that rely on precedent explicitly overruled by *Kingsdown*).

As it now stands, the test generally permits an inference of deceptive intent to be drawn whenever the three prongs are satisfied. This is in tension with the rule in *Star Scientific* that “the inference must not only be based on sufficient evidence and be reasonable in light of that evidence, but it must also be the *single most reasonable* inference able to be drawn from the evidence.” *Id.* at 1366 (emphasis added). It cannot be said that deceptive intent is the “single most reasonable inference” when all that prong two shows is that the patentee “should have known” that the information was material. An equally reasonable inference under this test is that the patentee incorrectly believed that the information was not material, or that the patentee was negligent, or even grossly negligent. None of these gives rise to deceptive intent under *Kingsdown*, nor is deceptive intent the “single most reasonable inference” under *Star Scientific*.

For the foregoing reasons, I respectfully submit that the test for inferring deceptive intent, as it currently exists, falls short of the standard “need[ed] to strictly enforce the burden of proof and elevated standard of proof in the inequitable conduct context.” *Star Scientific*, 537 F.3d at 1365. The facts of this case suggest that the time has come for the court to review the issue en banc.

C.A.Fed. (S.D.), 2009.
Larson Mfg. Co. of South Dakota, Inc. v. Aluminart Products Ltd.
559 F.3d 1317, 90 U.S.P.Q.2d 1257

END OF DOCUMENT

559 F.3d 1317, 90 U.S.P.Q.2d 1257
(Cite as: **559 F.3d 1317**)